

# Porte **VETRO** | ECLISSE **Classic Collection**

## CARATTERISTICHE TECNICHE

Il controtelaio per ante in vetro è il medesimo utilizzato per le porte in legno.

Le porte in vetro acquistate direttamente da ECLISSE hanno uno spessore di 10 mm e sono complete di staffe, guidaporta e maniglia di serie in vetrofusione (vedi la sezione "Maniglie" per scoprire l'intera gamma disponibile). È tuttavia possibile acquistare le sole pinze/staffe e far realizzare l'anta in vetro dal proprio vetraio.

Le porte in vetro non sono disponibili per ECLISSE Telescopica, ECLISSE Circular e ECLISSE Novanta.

### STAFFE

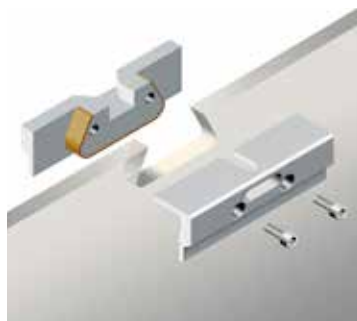
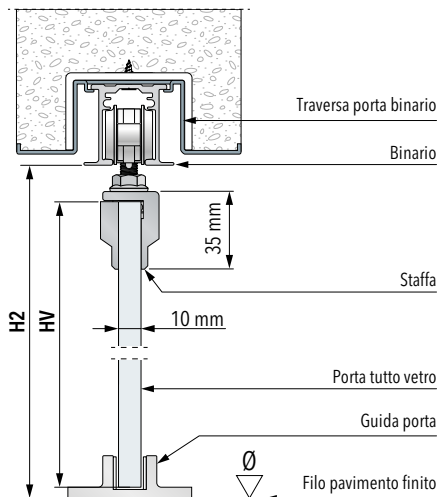

#### STAFFE

- Portata massima: 100 kg
- Dimensioni: L 100 x H 35 x SP 26 mm
- Spessore vetro: 10 mm
- Necessarie due incisioni sul vetro a "coda di rondine"

$$\text{ALTEZZA VETRO (HV)} = \text{H2} - 25 \text{ mm}$$

H2 è la distanza tra il pavimento finito e il filo binario di alluminio. Si consiglia di rilevare la quota in più punti lungo l'intera luce.

### PINZE

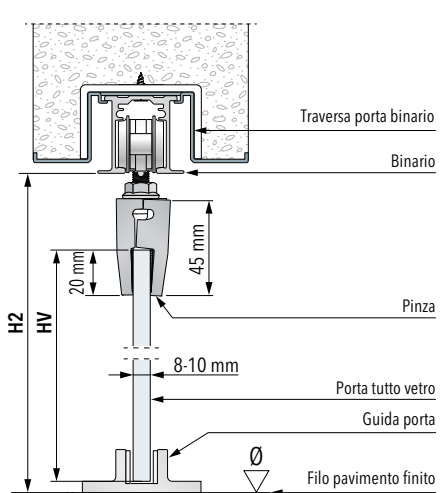

#### PINZE

- Portata massima: 80 kg
- Dimensioni: L 145 x H 45 x SP 27 mm
- Spessore vetro: 8 o 10 mm
- Si applicano direttamente sul pannello in vetro senza alcuna lavorazione precedente

$$\text{ALTEZZA VETRO (HV)} = \text{H2} - 46 \text{ mm}$$

H2 è la distanza tra il pavimento finito e il filo binario di alluminio. Si consiglia di rilevare la quota in più punti lungo l'intera luce.

### STIPITI E COPRIFILI | Disponibili in laminato bianco RAL 9010 e Noce Tanganika grezzo

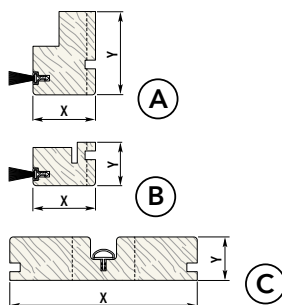
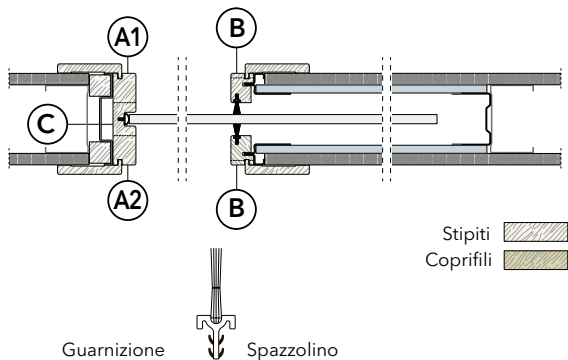

		SPESSORE PARETE			
		100	108	125	150
A	X	32	36	43	54
	Y	50	50	50	50
B	X	32	36	43	54
	Y	25	25	25	25
C	X	100	108	125	150
	Y	25	25	25	25

Misure espresse in mm

Lo stipite e il traverso superiore sono più larghi rispetto a quelli delle porte in legno e la sede di battuta dello stipite è adattata allo spessore dell'anta in vetro.

## FINITURE VETRO



TRASPARENTE



TRASPARENTE  
EXTRACHIARO



SATINATO



SATINATO  
EXTRACHIARO



FUMÉ  
TRASPARENTE



FUMÉ  
SABBIATO



SPECCHIATO  
ARGENTO  
(solo per ECLISSE  
Syntesis Collection)

Disponibili con o senza decoro (la finitura specchiato argento è disponibile solo senza decoro).

## DECORAZIONI

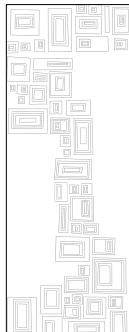

MIRAGE

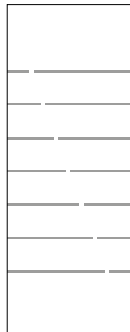

INTER-  
RUZIONE



PULL

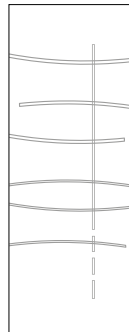

REGOLA

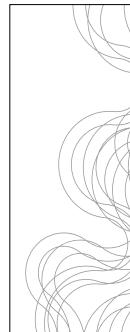

FIBRE



OPALE



CANNE  
AL VENTO



BRISTOL

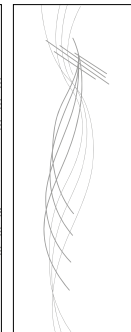

ROUEN

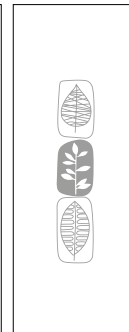

TREVIRI

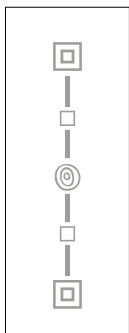

GEO

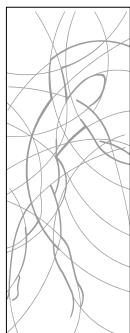

HAYLIN



RIFLESSI

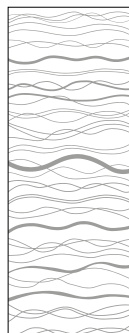

ACQUA



GREEN



DANZICA

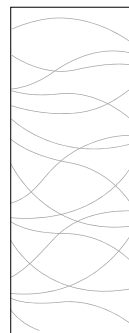

RONDA



REM

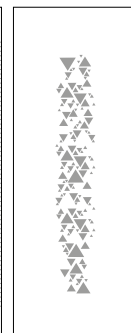

RAIPUR

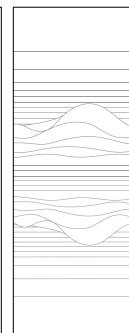

FIORDO

Su basi trasparente, trasparente extrachiaro, satinato, satinato extrachiaro e fumé trasparente il decoro è sabbiato.  
Su base fumé sabbiato il decoro è trasparente.

# Porte **VETRO**

## FINITURE COLORS | Effetto coprente (verniciatura monocoprente)



BIANCO 9010



BEIGE 1015



ARGENTO 9006



GRIGIO 7024



BLU 5002



ROSSO 3003



ARANCIONE 2001



VERDE 1027



NERO 9005

Pannello composto da due lastre di 5 mm accoppiate in vetro temperato stratificato con verniciatura interna monocoprente.

## FINITURE COLORS | Effetto satinato (verniciatura effetto satinato da un lato)



BIANCO 8105



AMBRA 8109



BLU 8133



ARANCIONE 8136

Pannello composto da una lastra unica di 10 mm in vetro temperato con verniciatura effetto satinato su un lato.